

OWNERS MANUAL

How to maintain and operate your
EcoWater electronic demand water system



MODEL
ESD 525



System Tested and Certified by NSF International and WQA
against NSF/ANSI Standard 44 for softener performance.

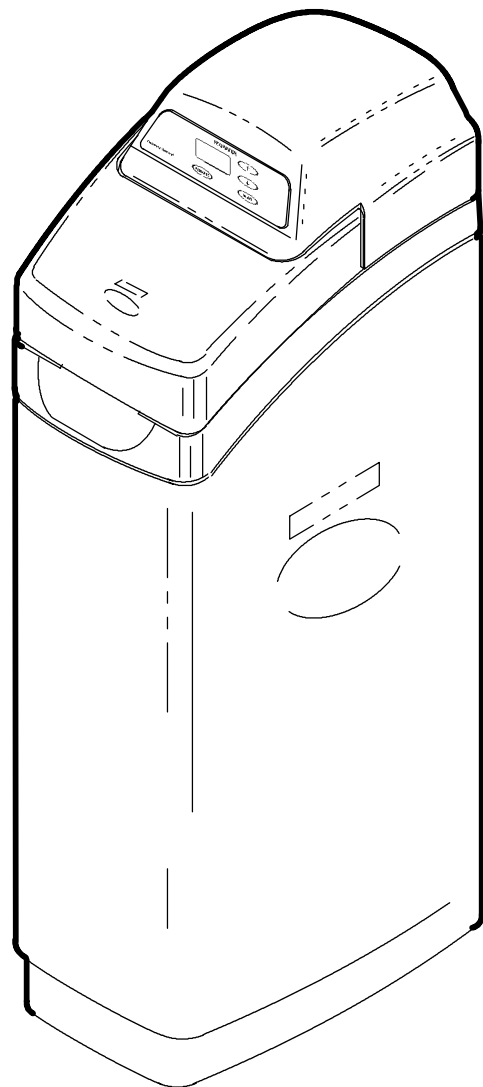

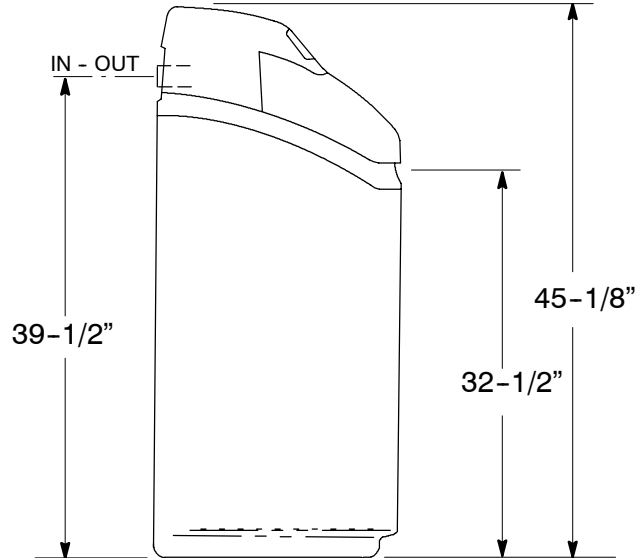
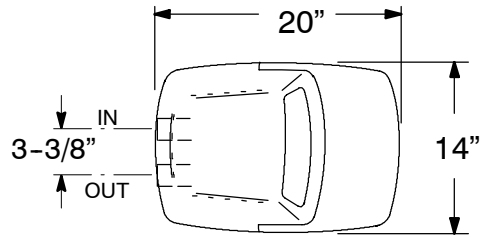

FOR FUTURE REFERENCE, ENTER THE FOLLOWING INFORMATION

MODEL NO. ①② _____	SERIAL NO. ①② _____
DATE CODE ② _____	INSTALLATION DATE _____
WATER HARDNESS _____ GPG	IRON CONTENT _____ PPM
WATER HARDNESS SETTING _____ (see page 15)	

① on rating decal ② on shipping carton

EcoWater Canada LTD
5240 Bradco Blvd. Mississauga, Ontario L4W 1G7
1 - 800 - 752 - 3273

UNPACKING

EcoWater Systems units are shipped from the factory in one master carton. The carton also includes a skin pack of small parts needed to assemble and install the unit, and this manual.

Thoroughly check the EcoWater System unit for possible shipping damage and parts loss. Also inspect and note any damage to the shipping carton. Notify the transportation company if damage is present. EcoWater is not responsible for in-transit damages.

Remove and discard (RECYCLE) all packing materials. We suggest you keep the small parts on the skin-pack until you are ready to use them.

TABLE OF CONTENTS

	Page
Dimensions / Specifications	2
Water / Water Conditioning	4-5
Assembly Instructions	6
Planning Installation	7
Installation Steps	8-11
Programming Face Plate-Timer	12-13
Features / Options	14-15
EcoWater System Unit Operation	16-17
Service Information	18-25
Repair Parts	26-29
Warranty	30

SAFETY GUIDES

Follow the installation instructions carefully. Failure to install the EcoWater softener properly **voids the warranty.**

Before you begin installation, read this entire manual. Then, obtain all the materials and tools you will need to make the installation.

Check local plumbing and electrical codes. The installation must conform to them.

Use only lead-free solder and flux for all sweat-solder connections, as required by state and federal codes.

Use care when handling the EcoWater softener. Do not turn upside down, drop, or set on sharp protrusions.

Do not locate the EcoWater softener where freezing temperatures occur. Do not attempt to treat water over 120°F. **Freezing, or hot water damage voids the warranty.**

Avoid installing in direct sunlight. Excessive sun heat may cause distortion or other damage to non-metallic parts.

The EcoWater softener requires a minimum water flow of 3 gallons per minute at the inlet. **Maximum allowable inlet water pressure is 125 psi.** If daytime pressure is over 80 psi, nighttime pressure may exceed the maximum. Use a pressure reducing valve if necessary. (Adding a pressure reducing valve may reduce the flow.)

The EcoWater softener works on 24 volt-60 hz electrical power only. Be sure to use the included transformer and plug it into a nominal 120V, 60 cycle household outlet that is grounded and properly protected by an over current device such as a circuit breaker or fuse. If transformer is replaced, use only the authorized service, Class II, 24 volt, 10 VA transformer.

This system is not intended to be used for treating water that is microbiologically unsafe or of unknown quality without adequate disinfection before or after the system.



European Directive 2002/96/EC requires all electrical and electronic equipment to be disposed of according to Waste Electrical and Electronic Equipment (WEEE) requirements. This directive or similar laws are in place nationally and can vary from region to region. Please refer to your state and local laws for proper disposal of this equipment.

WATER

Man's very existence depends on water. It is 1 of the basic commodities of life. Water is best as nature provides it, is a common misconception. Practically all natural water needs refinement or treatment to make it safe to drink or more satisfactory to use.

The earth's water supply cycle starts in the upper cloud layers. As it falls to the earth as rain or snow, it picks up impurities and gases from the atmosphere. Landing on earth, it seeps over and through the ground, dissolving earth minerals. Passing through limestone, it dissolves calcium and magnesium, the hardness minerals. Iron deposits impart iron to the water. Acidity and sediments are other water conditions.

Municipal water supplies come from surface reservoirs, such as lakes and rivers, or from underground reservoirs. Usually, municipalities chlorinate the water to make it safe to drink. Sediment is removed by filtration. Tastes and odors are reduced or eliminated. The water is conditioned to comply with certain specifications. However, hardness minerals, tastes and odors are not always reduced to the most desirable levels.

Underground reservoirs provide our private water supplies. Because the water is raw and untreated, it can have varying amounts of hardness, iron, tastes, odors, acidity, or combinations of these. Different localities and water levels affect mineral content.

WATER CONDITIONING

Water conditioning is the treatment of four general conditions. These are: (1) *Hardness*, (2) *Iron*, (3) *Acidity*, (4) *Sediments*.

(1) **HARDNESS** is a term to describe the presence of calcium and magnesium minerals in water. A chemical analysis accurately measures the amount of minerals in grain weight. For example, 1 gallon of water with 5 grains per gallon (gpg) hardness has dissolved minerals, that if solidified, about equals the size of 1 ordinary aspirin tablet. One gallon of water, 25 gpg hard, has a mineral content equal in size to 5 aspirin tablets. Water hardness varies greatly across the country. It generally contains from 3 to 100 gpg.

Hard water affects living in general. Hardness minerals combine with soap to make a soap curd. The curd greatly reduces the cleaning action of soap. Precipitated hardness minerals form a crust on cooking utensils, appliances, and plumbing fixtures. Even the tastes of foods are affected. A water softener removes the hardness minerals to eliminate these problems, and others. Pages 16-17 describe how the EcoWater conditioner works.

Sodium Information: Water softeners using sodium chloride (salt) for regeneration add sodium to the water. Persons on sodium restricted diets should consider the added sodium as part of their overall intake.

(2) **IRON** in water is measured in parts per million (ppm). The total* ppm of iron, and type or types*, is determined by chemical analysis. Four different types of iron in water are: ❶ Ferrous (clear water), ❷ Ferric (red water), ❸ Bacterial and organically bound iron, ❹ Colloidal and inorganically bound iron (ferrous or ferric).

*Water may contain one or more of the four types of iron and any combination of these. Total iron is the sum of the contents.

❶ Ferrous (clear water) iron is soluble and dissolves in water. It is usually detected by taking a sample of water in a clear bottle or glass. Immediately after taking, the sample is clear. As the water sample stands, it gradually clouds and turns slightly yellow or brown as air oxidizes the iron. This usually occurs in 15 to 30 minutes. An EcoWater conditioner will remove moderate amounts of this type of iron*.

*Capacity to remove clear water iron was tested in the field by the manufacturer.

❷ Ferric (red water), and ❸ Bacterial and organically bound irons are insoluble. This iron is visible immediately when drawn from a faucet because it has oxidized before reaching the home. It appears as small cloudy yellow, orange, or reddish suspended particles. After the water stands for a period of time, the particles settle to the bottom of the container. Generally these irons are removed from water by filtration. Chlorination is also recommended for bacterial iron. An EcoWater conditioner will remove minimal quantities (see specifications) of ferric iron.

continued

④ Colloidal and inorganically bound iron is a ferric or ferrous form that will not filter or exchange out of water. In some instances, treatment may improve colloidal iron water, but always **consult a qualified water chemistry lab** before attempting to treat it. Colloidal iron water usually has a yellow appearance when drawn. After standing for several hours, the color persists and the iron does not settle, but remains suspended in the water.

Iron in water causes stains on clothing and plumbing fixtures. It negatively affects the taste of food, drinking water, and other beverages.

(3) *ACIDITY* or acid water is caused by carbon dioxide, hydrogen sulfide, and sometimes industrial wastes. It is corrosive to plumbing, plumbing fixtures,

water heaters, and other water using appliances. It can also damage and cause premature failure of seals, diaphragms, etc., in water handling equipment.

A chemical analysis is needed to measure the degree of acidity in water. This is called the pH of water. Water testing below 6.9 pH is acidic. The lower the pH reading, the greater the acidity. A neutralizer filter or a chemical feed pump are usually recommended to treat acid water.

(4) *SEDIMENT* is fine, foreign material particles suspended in water. This material is most often clay or silt. Extreme amounts of sediment may give the water a cloudy appearance. A sediment filter normally corrects this condition.

COMPLETE WATER CONDITIONING SYSTEM - Seldom would all the water conditioners shown below be needed on one water supply. The drawing does show the proper sequence location of each conditioner. Note that only a taste and odor filter is installed after a water softener. All other filters belong before the water softener. Also note that outside faucet lines are before the treated water, and the water heater is after all conditioning.

NOTE: FOR CLARITY OF THIS DRAWING, NOT ALL WATER CONDITIONERS ARE ILLUSTRATED (REVERSE OSMOSIS SYSTEMS, DISTILLERS, ETC.).

Figure 1

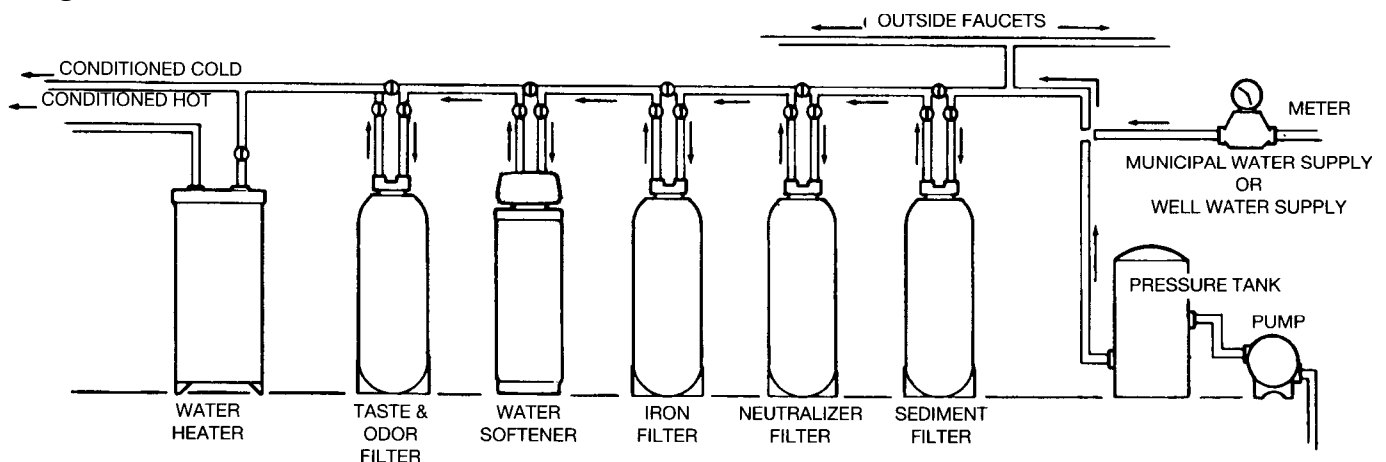
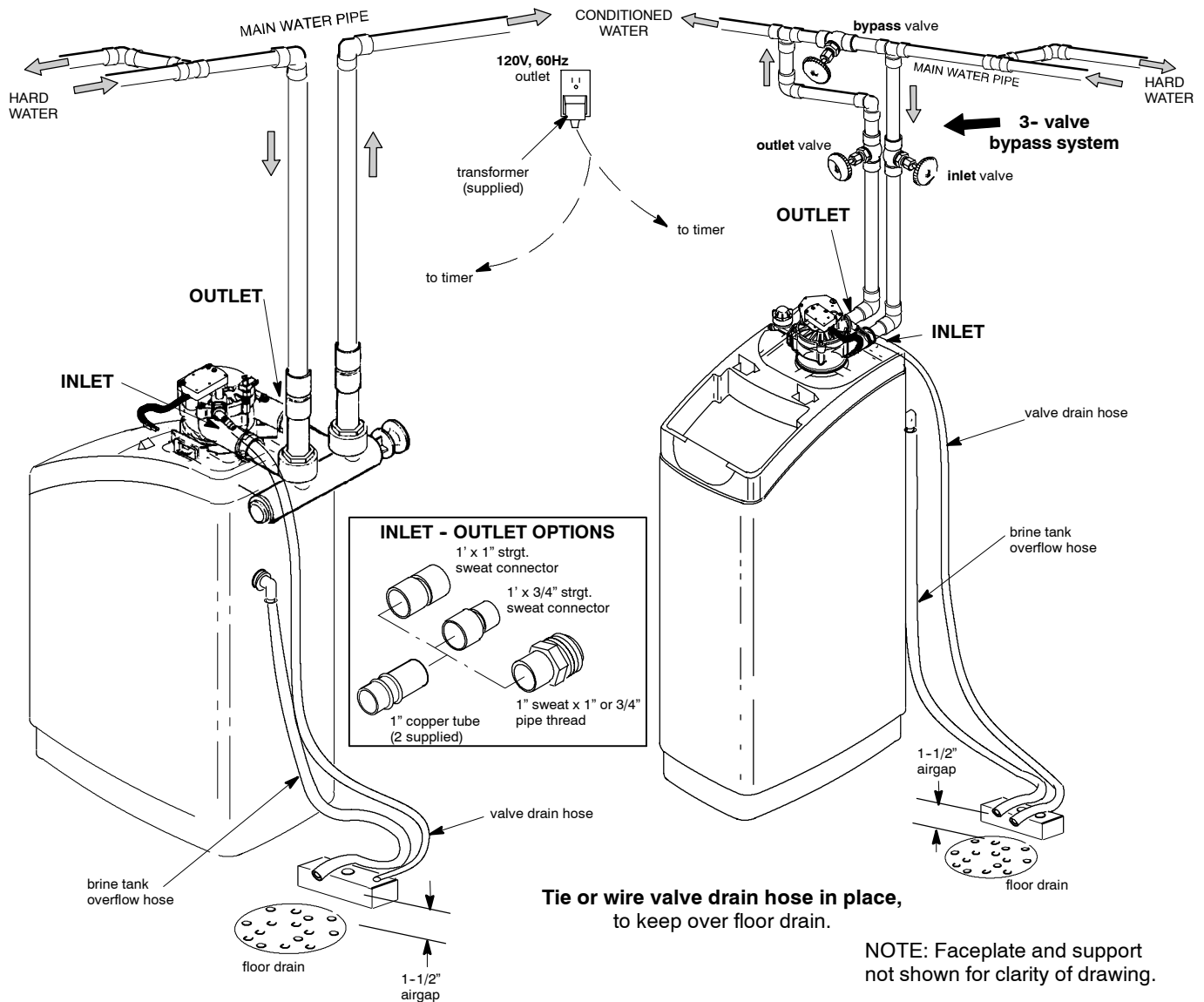

Figure 2

TYPICAL INSTALLATION DRAWINGS



INLET - OUTLET PLUMBING OPTIONS

- ALWAYS INSTALL either an EcoWater bypass valve, #7129871, or a 3 valve bypass system. Bypass valves allow you to turn off water to the softener for repairs if needed, but still have water in house pipes.
- Use 1" or 3/4" (minimum) pipe and fittings.
- Use sweat copper... or, threaded pipe*... or, PVC plastic pipe.*

*Sweat soldering is required to adapt to the fittings (1" male) supplied with the EcoWater System Unit, or obtain approved compression adaptors. The following special fittings are available from EcoWater. **Be sure to comply with all local plumbing codes.**

OPTIONAL INLET/OUTLET FITTINGS

- #7104546 PVC Nipple – Use in place of included copper inlet and outlet tubes.
- #7129211 Adaptor Fitting, 1-1/2" (2) – Use in place of included copper inlet and outlet tubes.
- #7120259 Elbow – Extends inlet and/or outlet in any 90° direction.

OTHER REQUIREMENTS

- A drain is needed for regeneration discharge water. A floor drain is preferred, close to the EcoWater conditioner. A laundry tub, standpipe, etc., are other drain options.

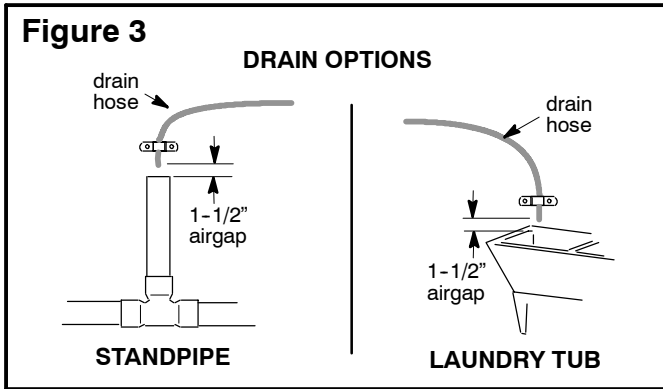

- A 120V-60Hz, grounded, continuously “live”, electrical outlet is needed within 10’ of the EcoWater conditioner.

TOOLS YOU MAY NEED

- common screwdriver
- cross-point screwdriver
- pliers
- tape measure

SOLDERED COPPER THREADED CPVC PLASTIC

- | | | |
|--|--------------------------|---------------------|
| • tubing cutter | • hacksaw or pipe cutter | • hacksaw |
| • propane torch | • threading tool | • adjustable wrench |
| • LEAD-FREE solder and flux | • pipe joint compound* | • solvent cement* |
| • emery cloth, sandpaper or steel wool | | • primer |

MATERIALS YOU MAY NEED

- bypass valve, or 3 valves
- pipe and fittings as required
- 7/16” I. D. high quality, flexible hose for the valve drain,* and brine tank drain.

*VALVE DRAIN OPTIONS: Flexible drain hose is not allowed in all localities (check your codes). To make a rigid valve drain run, cut the barbed section off the drain fitting for access to the 1/4” pipe threads. Then plumb a rigid drain as needed. Purchase a fitting, as needed, to adapt rigid tubing to the 1/4” threads.

Figure 4

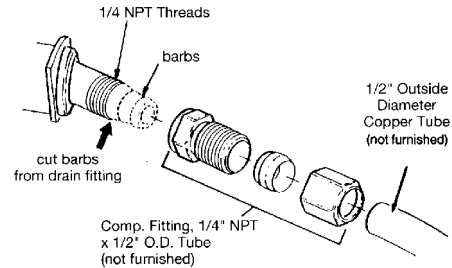

SELECT INSTALLATION LOCATION

Consider all of the following when selecting an installation location for the EcoWater conditioner.

- To condition all water in the home, install the EcoWater conditioner close to the water supply inlet, and before all other plumbing connections, **except** outside water pipes. Outside faucets should remain on hard water to avoid wasting conditioned water and salt (see drawing on page 6).
- A nearby drain is needed to carry away regeneration discharge water. A floor drain is preferred, with a laundry tub, standpipe, etc., as other options (check your local codes).
- **The EcoWater conditioner works on 24 volts only.** A transformer is included to reduce 120V-60 Hz house power. Provide an approved, grounded outlet within 10’ of the conditioner. The transformer has an attached 10’ power cable for connection between the outlet and the timer.
- Position the EcoWater conditioner at least 6” from surrounding walls, or other appliances, to allow access for adding salt and servicing.
- Locate the EcoWater conditioner, in the plumbing system, **after** all other installed water conditioning equipment, except for a taste and odor filter. A taste and odor filter is installed after all equipment. **Always install the EcoWater conditioner BEFORE the water heater.** See the Safety Guides on page 3. To reduce the risk of hot water back-up, conditioned water piping between the EcoWater conditioner and water heater should be as long as possible.
- Install the EcoWater conditioner in a place water damage is least likely to occur if it develops a leak.
- If installing the conditioner in an outside location, be sure to provide protection from the elements, contamination, vandalism, and sunlight heat. The sun’s heat can melt plastic parts.

1. Close the shut-off valve on the house main water pipe, near the water meter or pressure tank, to turn off the water.

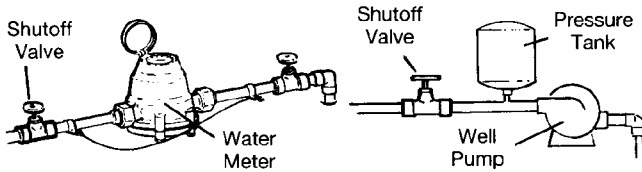

2. Shut off the gas or electric supply to the water heater.

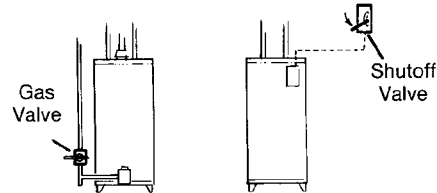

3. Open the highest and lowest water faucets in your house to let water drain from the pipes. Close faucets after water has drained.

4. If not already done, remove all cardboard or plastic packing pieces from inside the softener.

5. INSTALL INLET AND OUTLET ADAPTORS, OR THE OPTIONAL BYPASS VALVE.

IMPORTANT: On electronic demand models, be sure the turbine, turbine support and sensor housing are firmly in position, in or on the valve outlet.

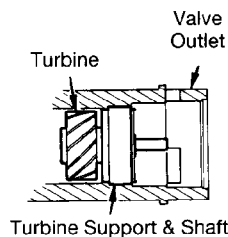

- **INLET AND OUTLET ADAPTORS** – Push adaptors into the valve ports. Be sure the o-ring seals are lubricated with silicone grease or Vaseline.

– OR –

BYPASS VALVE – Push the bypass valve into the valve ports (can be inverted for connecting to floor level plumbing). Be sure the o-ring seals are lubricated with silicone grease or Vaseline.

- **SNAP THE 2 LARGE HOLDING CLIPS INTO PLACE, FROM THE TOP DOWN AS SHOWN. BE SURE THEY SNAP FIRMLY INTO PLACE, SO THE ADAPTORS, OR BYPASS VALVE, DO NOT PULL OUT.**

Figure 5

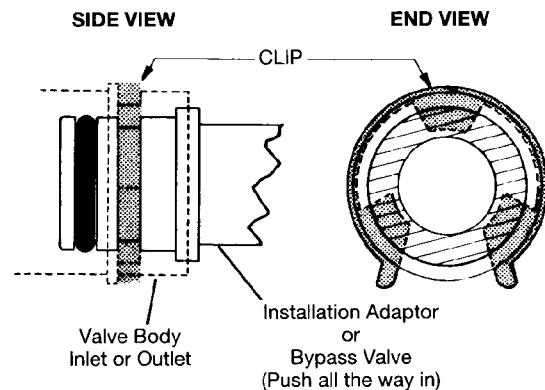
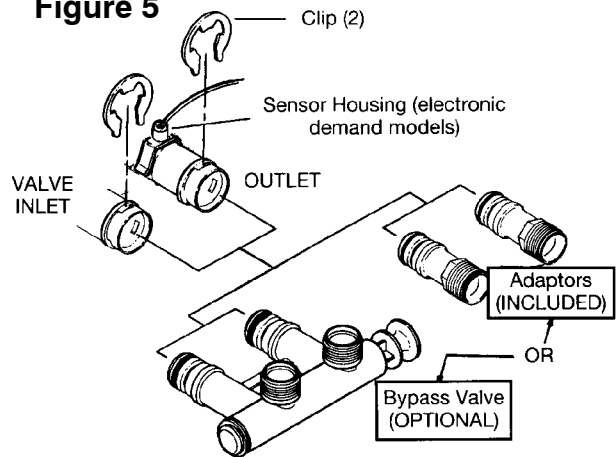

NOTE: O-RING SEALS PLACED IN OUTER GROOVES ONLY. CLIPS SNAP INTO INNER GROOVES.

6. Move the softener into installation position, setting on a smooth and level surface. If needed, set it on a piece of 3/4" thick plywood (slightly larger than the bottom of the brine tank). Then shim under the plywood to level the softener.
7. Referring to page 6, run inlet and outlet pipes to the softener, observing all of the following notes.
 - If the optional bypass valve is not used, be sure to use a 3-valve bypass as typically shown in figure 2.
 - Be sure to plumb so HARD WATER flows TO the softener valve INLET.
 - If sweat soldering, first disconnect copper pipes from plastic softener parts. **DO NOT SOLDER WITH COPPER CONNECTED TO THE SOFTENER OR PLASTIC PARTS WILL BE DAMAGED.**
 - If using threaded fittings, use extreme care not to cross-thread onto plastic.
 - Support inlet-outlet plumbing in some manner, to keep the weight off of the softener valve.

8. **CONNECT THE VALVE DRAIN HOSE**
Attach a length of 7/16" I.D. hose to the valve drain fitting. Use a hose clamp to hold it in place. Place the other end of the hose over a floor drain, into a laundry tub, sump, stand-pipe or other suitable drain (see page 7). **BE SURE TO OBSERVE YOUR LOCAL CODES.**

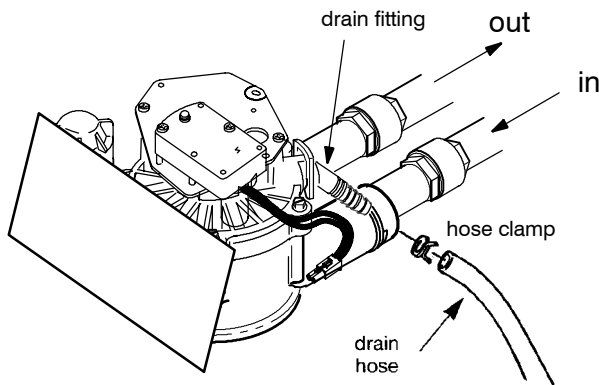

IMPORTANT NOTES:

Leave an air gap of about 1-1/2" between the end of the hose and the drain. This gap is needed so you don't get a back-flow of sewer water into the softener. **DO NOT** put the end of the hose into the drain or connect without the air gap.

Place and support the hose so it does not kink or have sharp bends. Tie or wire the hose in place so water pressure will not make it "whip." Do not pinch the hose shut. **THE SOFTENER WILL NOT WORK IF THIS DRAIN HOSE IS PINCHED, PLUGGED OR CLOSED IN ANY WAY.**

Keep the hose lower than the drain fitting. (In some homes, to get to a drain you must raise the hose and run it over-head. If you need an overhead drain, do not raise the hose more than 8' above the floor. A copper drain tube is best to use.)

9. CONNECT BRINE TANK OVERFLOW HOSE

Insert the rubber grommet into the hole provided in the brine tank wall. Push the hose adaptor elbow into the grommet.

Attach a length of 7/16" I.D. hose to the drain elbow, securing with a clamp. Place the opposite end of the hose over the floor drain.

NOTE: This is a gravity drain. **DO NOT ELEVATE THE HOSE HIGHER THAN THE HOSE ADAPTOR ELBOW.**

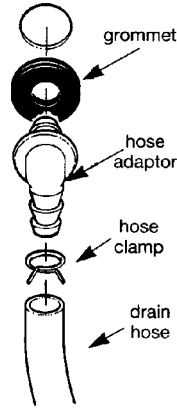

10. The house cold water pipe (metal only) is often used as a ground for the house electrical system. The 3-valve bypass type of installation, shown in figure 2, will maintain ground continuity. If you use the plastic bypass valve at the water softener, continuity is broken. To restore the ground, install 1 of the following grounds.

- Use the included ground clamp kit to jump across the inlet and outlet copper tubes.
- Install a #4 copper wire across the removed section of main water pipe, securely clamping on both ends.

A

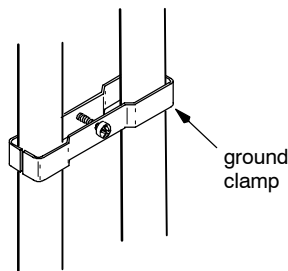

B

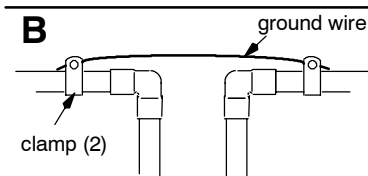

11. PRESSURE TESTING FOR LEAKS – TO PREVENT EXCESSIVE AIR PRESSURE IN THE WATER SOFTENER AND PLUMBING SYSTEM, DO THE FOLLOWING STEPS IN ORDER.

- Open 2 or more soft water faucets, both hot and cold.
- Referring to figure 3, move the bypass valve(s) to SERVICE position.
- SLOWLY OPEN THE MAIN WATER SUPPLY VALVE. When water from the faucets runs smoothly, with no air bubbles, close the faucets.
- Check your complete installation for leaks. If rework is required, be sure to observe precautions in step 7.

Figure 6

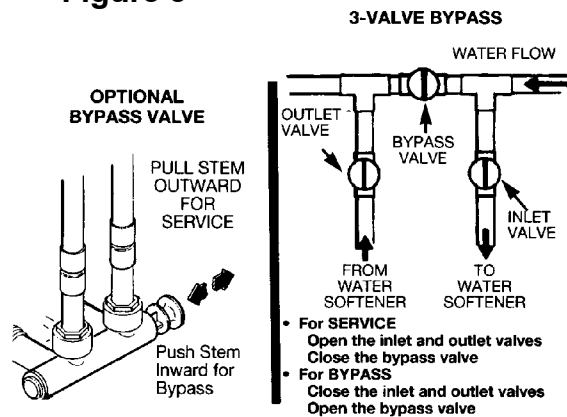

Bypass valve(s) should always remain in softwater service position. Position in "bypass" only if needed for softener repair.

12. ADD WATER AND SALT INTO BRINE TANK

- Using a pail, or garden hose, add about 2 gallons of water into the brine tank. **DO NOT POUR INTO THE BRINEWELL.**
- **FILL THE BRINE TANK WITH SALT.** You can use most water softener salts, but it must be clean (recommended NUGGET or PELLET salt has less than 1% impurities). Salt storage capacity is shown on the specification page.

NOTE: See page 18 for additional salt information.

13. SANITIZING THE WATER SOFTENER

Care is taken at the factory to keep your water softener clean and sanitary. Materials used to make the water softener will not infect or contaminate your water supply, and will not cause bacteria to form or grow. However, during shipping, storage, installing and operating, bacteria could get into the water softener. For this reason, sanitizing, as follows, is suggested ① when installing.

. . .Remove the brinewell cover and pour about 1-1/2 oz. of common household bleach (Clorox, Linco, BoPeep, White Sail, Eagle, etc.) into the softener brinewell (see page 26). **REPLACE THE BRINEWELL COVER.**

① Recommended by the Water Quality Association. On some water supplies, the water softener may need periodic disinfecting.

14. CONNECT TO ELECTRICAL POWER

- Plug the transformer into a continuously “live,” grounded, 120V-60 Hz house electrical outlet, approved by local codes.

15. PROGRAM THE TIMER...page 12. AFTER PROGRAMMING, COMPLETE INSTALLATION STEPS 16 AND 17 BELOW.

16. START A RECHARGE

This initial recharge draws the sanitizing bleach (step 13) into and through the water softener, and purges any air remaining in the system. To start this recharge, which lasts for about 2 hours, do the following.

ELECTRONIC DEMAND

Press and hold in (for 3 seconds) the RECHARGE button, until RECHARGE begins to flash in the display.

- 17.** Install the top cover, then the salt fill hole cover.

THE INSTALLATION IS COMPLETE.

Figure 7

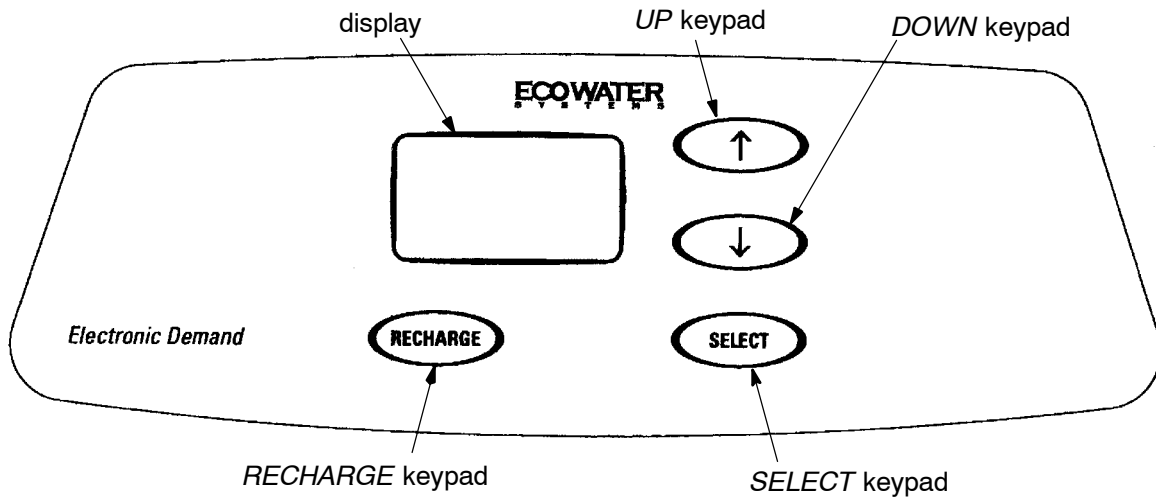

When the transformer is plugged in, a model code shows in the face plate display for the first few seconds. The model code for your water softener is **SR22**, as shown in the following drawing. The model code is followed by a test number (example: J1.0). After the test number, 12:00 PM and the words “PRESENT TIME” begin to flash in the display.

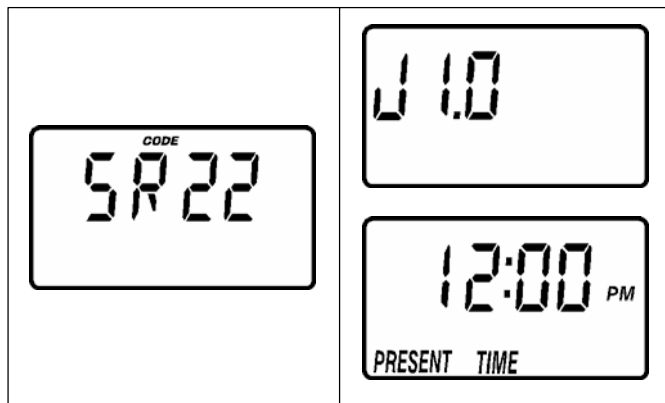

NOTE: If - - - - is flashing in the display, press the UP (↑) keypad (FIG. 7) until SR22 shows, as needed for your model. **Be sure to set the correct code.** Then, press the SELECT keypad to display the flashing 12:00 PM. **If other than SR22 shows,** when the transformer is first plugged in, please see page 21 to reset.

SOUND “BEEPER”: A “beeper” sounds while pressing keypads for timer set-up. One beep signals

a change in the face plate display. Repeated beeps means the timer will not accept a change from the keypad you have pressed, telling you to use another keypad. For example, in setting the hardness (step 2), the beeper sounds repeatedly when the display reaches 1 using the DOWN keypad, or the highest hardness setting using the UP keypad.

1. SET PRESENT TIME OF DAY:

NOTE: If the words PRESENT TIME do not show in the display, press the SELECT keypad (FIG. 7) until they do.

Press the (↑) UP/DOWN (↓) keypads to set the present time. Press UP to move the display ahead; press DOWN to move the time backward.

If the present time is between noon and midnight, be sure PM shows.



If the present time is between midnight and noon, be sure AM shows.



NOTE: Each press of the UP or DOWN keypads changes the time by one minute. Pressing and holding the keypads changes the time 32 minutes each second.

2. SET WATER HARDNESS NUMBER:

Press the SELECT keypad once to display 25 (flashing) and HARDNESS.

Set the grains per gallon hardness of your water supply (determined by water analysis or call your local water department).



NOTE: If your water supply contains iron, compensate for it by adding to the water hardness number. For example, assume your water is 15 gpg hard and contains 2 ppm iron. Add 5 to the hardness number for each 1 ppm of iron. In this example, you would use 25 for your hardness number.

$$2 \text{ ppm iron} \times 5 = 10 \text{ (times)} \quad \begin{array}{r} 15 \text{ gpg hardness} \\ +10 \\ \hline 25 \text{ HARDNESS NUMBER} \end{array}$$

Press the (↑) UP/DOWN (↓) keypads to set your water hardness number in the display. The DOWN keypad moves the display to 1. The UP keypad moves the display to the highest setting (see maximum setting for your model in the specifications).

NOTE: Each press of the UP/DOWN keypad changes the display by 1 between 1 and 25. Between 25 and the highest number, the display changes 5 at a time 25, 30, 35, etc. Continuous pressure on the UP or DOWN keypad changes the display twice each second.

NOTE: If using potassium chloride (KCl) instead of standard sodium chloride (NaCl) water softener salt, hardness setting must be increased by 25%.

3. SET RECHARGE (REGENERATION) TIME:

Press the SELECT keypad once to display 2:00 AM (flashing) and RECHARGE TIME.

At the 2:00 AM RECHARGE TIME setting, the softener begins regeneration at 2:00 AM, ending no later than 4:00 AM. This is a good time in most households because water is not being used.



If a different RECHARGE TIME setting would be better for your household, do the following.

Press the (↑) UP/DOWN (↓) keypads to set the desired RECHARGE starting hour. Be sure to observe the AM-PM as you did when setting the time of day.

NOTE: Each press of the UP/DOWN keypads changes the display 1 hour. Continuous pressure on the UP or DOWN keypad changes the display twice each second.

4. SET EFFICIENCY, BACKWASH TIME AND RINSE TIME:

Press and hold the SELECT button. "000--" should show in display. Press SELECT button once more to go to Efficiency screen.

Press the UP or DOWN button to set the efficiency setting either on or off.

NOTE: When efficiency setting is set to on, an icon will show in the upper right hand corner of the display.

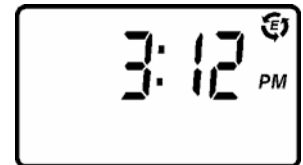

Press the SELECT button once to go to the backwash time setting.

NOTE: Factory default for this setting is 7 minutes.

Press the UP or DOWN button to set the desired backwash time.

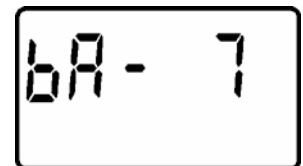

Press the SELECT button once to go to the rinse time setting.

NOTE: Factory default for this setting is 3 minutes.

Press the UP or DOWN button to set the desired rinse time.

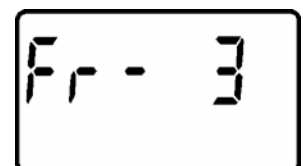

Press the SELECT keypad once again, to return the present time (steady) of day.

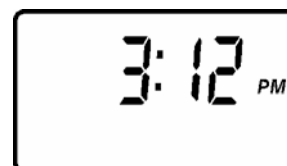

EXTRA RECHARGE

Sometimes, a manually started regeneration (re-charge) may be desired, or needed. Two examples are:

- You have used more water than usual (guests visiting) and you may run out of soft water before the next timer started regeneration.
- You did not refill the softener with salt before it was gone.

You can start a regeneration right away, or you can set the timer to regenerate at the next 2:00 AM (or other preset recharge time). Do the following.

RECHARGE NOW

Press the RECHARGE keypad and *hold for 3 seconds*. RECHARGE NOW begins to flash in the display, and the softener enters the fill cycle of regeneration right away. This regeneration will last for about 2 hours. Then, you will have soft water again.



RECHARGE TONIGHT

Press and release (**do not hold**) the RECHARGE keypad. RECHARGE TONIGHT flashes in the display, and the softener begins regeneration at the next preset recharge time. If you decide to cancel the regeneration before it has started, press and release the RECHARGE keypad once more to turn off the flashing RECHARGE TONIGHT.



PROGRAM MEMORY

If electrical power to the softener goes off, the time display is blank but the face plate timer keeps the correct time for about 6 hours. When electrical power comes on again, you have to reset the present time **only** if the display is flashing. The HARDNESS and RECHARGE TIME never require resetting unless a change is desired.

Even if the timer is incorrect after a long power outage, the softener works as it should to keep your water soft. However, regenerations may occur at the wrong time of day until you reset the timer to the correct time of day.

ERROR CODE

An error code could appear in the face plate display if a problem occurs in the softener electronics. If you see an error code instead of the time of day, see page 20.

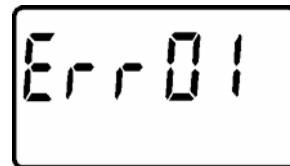

WATER METER:

The water meter, consisting of a turbine, turbine mounting assembly, and the sensor housing, is located at the valve outlet port. As water passes through and spins the turbine, two magnets (in the turbine) cause a back-and-forth movement of a switch in the sensor housing. This switch movement sends a pulse to the electronic demand timer.

ELECTRONIC DEMAND TIMER:

The demand timer is actually a small computer. As it receives pulses from the water meter, it converts them to gallons of water passing through the water softener. It multiplies this water usage information times the water hardness (preprogrammed into timer) to continually calculate the soft water capacity required. The computer adjusts daily to water using habits, seeking to supply soft water for the longest time, using the least (and most efficient) amount of salt and water to regenerate.

When the computer determines more capacity is needed, at the next regeneration starting time (2:00 a.m., or as otherwise preset), it will schedule a regeneration. RECHARGE TONIGHT shows in the display to inform of the coming regeneration.

WIRING SCHEMATIC

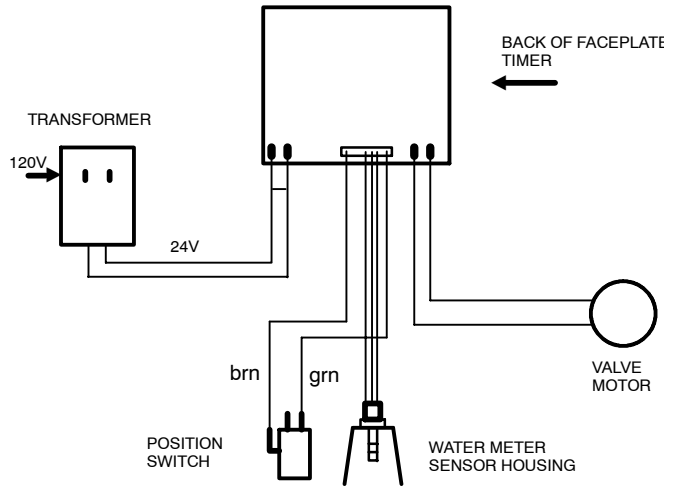

The water softener is filled with a man-made resin material. It is called the resin bed. The resin looks somewhat like coarse sand, but the beads are round and smooth. This resin has the ability to remove hardness minerals from water by ion-exchange.

SERVICE, AND REGENERATION

SERVICE (FIGURE 8):

Hard water enters the valve inlet port. Internal valve porting routes the water down and out the top distributor, into the resin tank. Hard water is softened as it passes through the resin bed, then enters the bottom distributor. Soft water flows back into the valve and out the valve outlet, to the house soft water pipes.

In time, the resin beads become coated with hardness minerals and cleaning with a salt solution (brine) is needed to remove it. Regeneration, and recharge, are words used to describe this cleaning.

Figure 8 SERVICE CYCLE

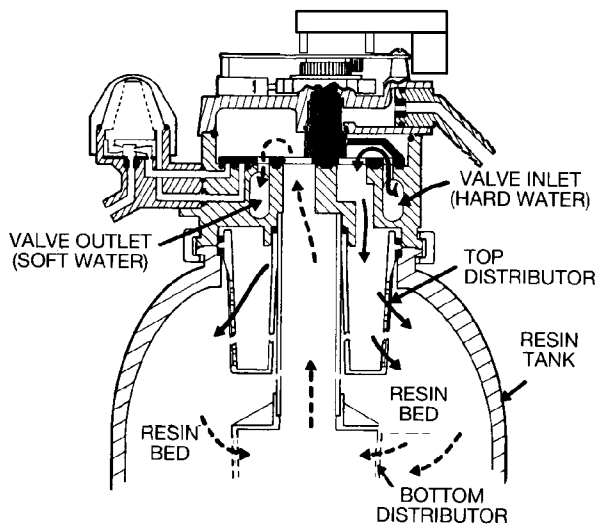

REGENERATION, OR RECHARGE

The face plate-timer determines when a regeneration is needed (see page 13). Regeneration starts at 2:00 a.m., or other preselected time, and consists of 5 different steps, or cycles.

NOTE: See the service information table, page 25, for regeneration cycle times.

STEP 1 – FILL CYCLE (FIGURE 9): Salt, dissolved in water, is called brine. Brine is the cleaning agent for the resin bed. To make brine, water is needed in the brine tank salt storage area. A controlled water flow to the brine tank takes place during fill.

The timer energizes the circuit to the valve motor. The valve motor rotates the rotor and disc and the valve cam until the position switch lever drops, to open the motor circuit and position the valve in FILL. As the rotor and disc rotates, the port opens for SOFT water fill through the venturi. Fill flow continues to the brine valve, and into the brine tank. Soft water is still available to the house lines.

Figure 9 FILL CYCLE

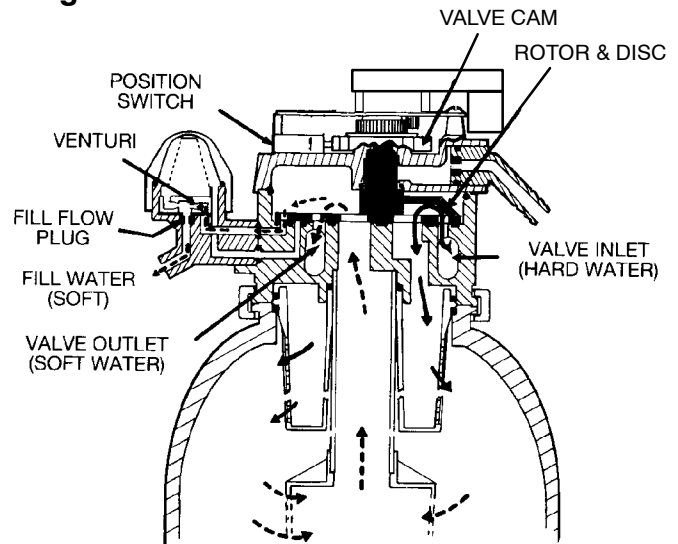

STEP 2 – BRINING CYCLE, and STEP 3 – BRINE RINSE CYCLE (FIGURE 10):

After fill, timer/switch action allows the motor to turn the rotor and disc into BRINING position. Water flow is directed to the nozzle. Suction, created by the nozzle and venturi, draws brine from the brine tank and injects it into the resin bed via the bottom distributor. Flow continues out the top distributor and to the drain. Hard water is available at the valve outlet.

BRINING, BRINE RINSE – continued

When the brine valve closes to end brine draw, water flow continues in the same directions to slowly RINSE brine from the resin bed and to the drain.

BRINING AND BRINE RINSE CYCLES

Figure 10

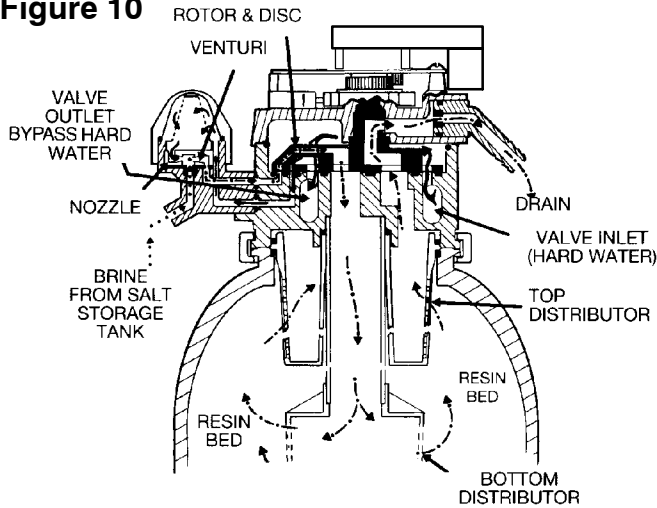

STEP 4 – BACKWASH CYCLE (FIGURE 11):

Timer/switch action again allows the motor to turn the rotor and disc to place the valve in BACKWASH, stopping water flow to the nozzle. Water is routed down and out the bottom distributor, up through the bed, and out the top distributor to the drain. The fast flow (controlled by a flow plug in the drain fitting) flushes dirt, sediments, iron deposits, remaining brine and hardness to the drain.

Figure 11 BACKWASH CYCLE

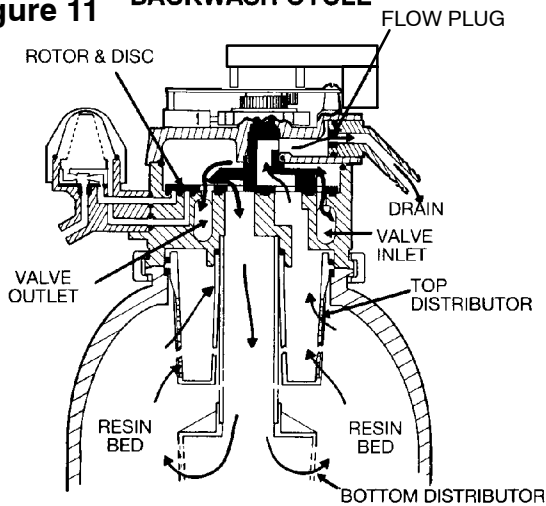

STEP 5 – FAST RINSE CYCLE (FIGURE 12):

During FAST RINSE, the rotor and disc is positioned so water flow enters the resin tank through the top distributor, and exists through the bottom distributor, to the drain.

The timer again energizes the motor to return the valve to service. As the valve rotates, the position switch lever drops to open the circuit. The valve remains positioned in service until the timer initiates the next regeneration.

Figure 12 FAST RINSE CYCLE

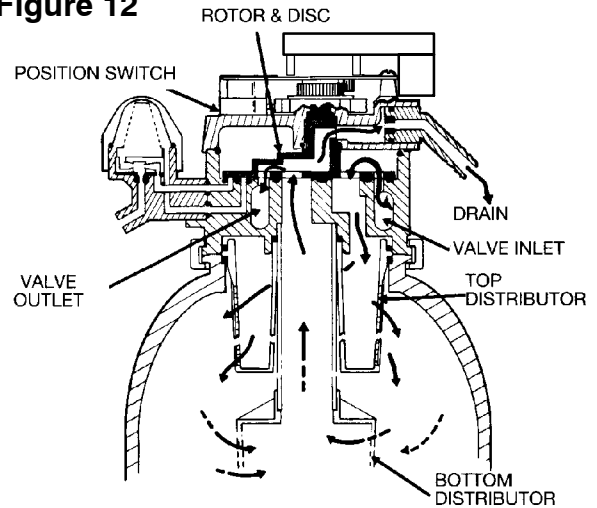

BYPASS HARD WATER: During brining, brine rinse and backwash, hard water is bypassed through the valve and available at house faucets. Avoid using HOT water however, because the water heater will refill with hard water.

VALVE CYCLE POSITION INDICATOR

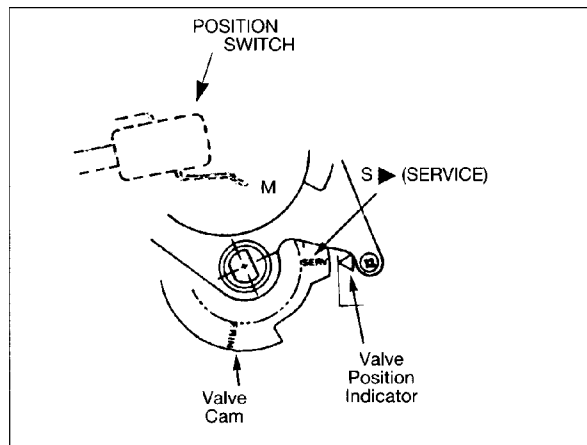

REFILLING WITH SALT

Remove the brine tank cover and check the salt storage level frequently. If the unit uses all the salt before you refill it, you will get hard water. Until you have established a refilling routine, check the salt every 2 or 3 weeks. ALWAYS refill if less than 1/2 full. **Be sure the brinewell cover is on.**

RECOMMENDED SALT: Cube, pellet, coarse solar, etc., water conditioner salt is recommended. This type of salt is from high purity evaporated crystals, sometimes formed, or compressed, into briquets. It has less than 1% insoluble (will not dissolve in water) impurities. *Clean, high grade* rock salts are acceptable, but may require frequent brine tank cleaning to remove the “sludge” residue (insolubles). **NOTE:** If using potassium chloride (KCl) instead of standard sodium chloride (NaCl) water softener salt, hardness setting must be increased by 25%.

SALT NOT RECOMMENDED: Rock salt, high in impurities, block, granulated, table, ice melting, ice cream making salts, etc., are not recommended.

SALT WITH IRON REMOVING ADDITIVES: Some salts have an additive to help a water conditioner handle iron in a water supply. Although this additive may help keep the resin bed clean, it may also release corrosive fumes that will weaken and shorten the life of some EcoWater System Unit parts.

BREAKING A SALT BRIDGE

Sometimes, a hard crust or salt bridge forms in the brine tank. It is usually caused by high humidity or the wrong kind of salt. When the salt bridges, an empty space forms between the water and the salt. Then, salt will not dissolve in the water to make brine. Without brine, the resin bed does not regenerate and you will have hard water.

If the storage tank is full of salt, it is hard to tell if you have a salt bridge. Salt is loose on top, but the bridge is under it. Take a broom handle, or like tool, and push it straight down into the salt. If a hard object is felt, it’s most likely a salt bridge. *Carefully* push into the bridge in several places to break it.

NOTE: *In humid areas, it is best to keep the salt storage level lower, and to refill more often.*

CLEANING THE NOZZLE AND VENTURI

A clean nozzle and venturi (FIG. 13) is a must for the EcoWater System Unit to work right. This small unit creates the suction to move brine from the brine tank, into the resin tank. If it should become plugged with sand, silt, dirt, etc., the EcoWater System Unit will not work, and you will get hard water.

To get to the nozzle and venturi, remove the EcoWater System Unit top cover. **Be sure the unit is in service cycle** (no water pressure at nozzle and venturi). Then, holding the nozzle and venturi housing with one hand, turn off the cap. *Do not lose the o-ring seal.* Lift out the screen support and screen. Then, remove the nozzle and venturi. Wash the parts in warm, soapy water and rinse in fresh water. If needed, use a small brush to remove iron or dirt. Be careful not to scratch, misshape, etc., surfaces of the nozzle and venturi. Also, check and clean the gasket and flow plug(s) if dirty.

Carefully replace all parts in the correct order. Lubricate the o-ring seal with silicone grease and locate in position. Install and tighten the cap, **by hand only.** **Do not overtighten** and break the cap or housing.

Figure 13

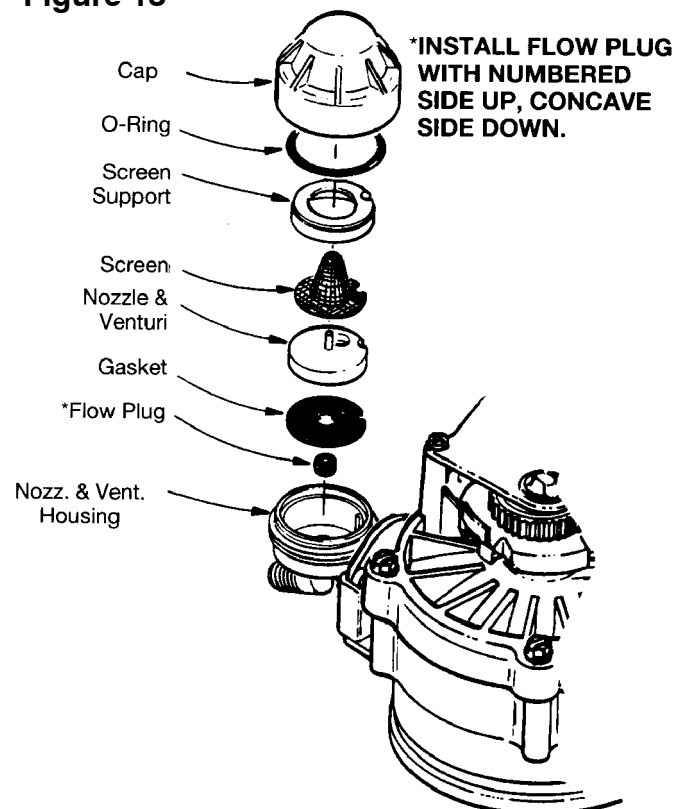

RESIN BED CLEANING

If the water supply contains “clear water” iron (see page 13), regular resin bed cleaning is needed to keep the bed from coating with iron. Use resin bed cleaner, available from EcoWater, following directions on the container. Clean the resin every 6 months, or more often if iron appears in your conditioned water supply.

ADDING RESIN

Normally, the resin bed (FIG. 14) will last the lifetime of the EcoWater System Unit. However, certain conditions may require partial or total replacement of the resin bed. Some of these conditions are:

- (1) damaged top and/or bottom distributors have allowed resin to escape
- (2) resin bed iron fouled beyond use
- (3) some water supplies cause resin degradation

MODEL NUMBER	RESIN TANK SIZE	FREEBOARD RANGE	LBS. RESIN PER INCH BED DEPTH
ESD 525	10 x 35"	8" - 10"	2.2

Figure 14

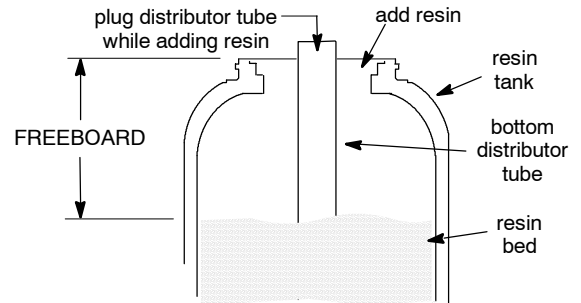

IMPORTANT NOTES:

- Turn off the water supply and relieve pressure...see below.
- Handle the resin tank carefully. It is heavy when filled with resin and water.
- Do not lose o-ring seals or other small parts.
- Refer to the assembly instructions and to installation steps to reassemble and restart the unit.

CAUTION: ALWAYS relieve water pressure in the EcoWater System Unit, as follows, before removing parts from the valve or resin tank.

DE-PRESSURIZE

- 1. Put bypass valve(s) in bypass position.
- 2. Do Manual Advance step 1, page 23, (fill water to brine tank will depressurize the resin tank).

PRESSURIZE

- 1. Put bypass valve(s) in service position.
- 2. Do Manual Advance steps 2-5, page 23, to return unit to service.

ALTERNATE METHOD

3-VALVE BYPASS

DE-PRESSURIZE

- 1. Close the INLET valve.
- 2. Open HOT and COLD conditioned water house faucets.
- 3. Close the OUTLET valve and open the BYPASS valve.
- 4. Close all house faucets.

PRESSURIZE

- 1. Open HOT and COLD house faucets.
- 2. Close the BYPASS valve and open the OUTLET valve.
- 3. **Slowly**, open the INLET valve.
- 4. Close all house faucets

ECOWATER BYPASS VALVE

DE-PRESSURIZE

- 1. Close the house main water supply valve.
- 2. Open HOT and COLD **conditioned** water faucets.
- 3. Push or rotate the bypass valve handle to bypass position.

Note: For hard water bypass to house faucets, reopen the main water supply valve.

PRESSURIZE

- 1. Open HOT and COLD house faucets (main water supply valve open).
- 2. Pull or rotate the bypass valve handle to service position.
- 3. Close all house faucets.

EcoWater Bypass Valve

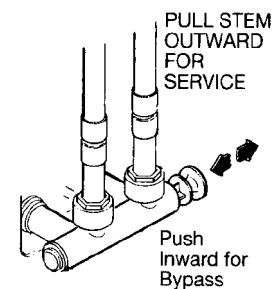

3 - Valve Bypass

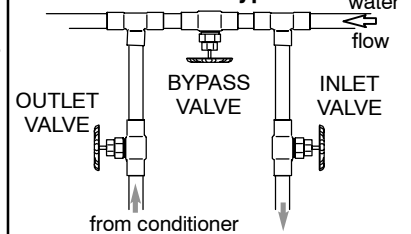

- for **SERVICE:**
 - Open the inlet and outlet valves.
 - Close the bypass valve.
- for **BYPASS:**
 - Close the inlet and outlet valves.
 - Open the bypass valve.

TROUBLESHOOTING

ALWAYS MAKE THE INITIAL CHECKS FIRST

INITIAL CHECKS:

1. Does the time display show the correct time of day?
...If display is blank, check power source to the EcoWater System Unit.
...If time is flashing, power was off for over two days. The unit resumes normal operation, when power returns, but regenerations occur at the wrong time.
...If an error code shows in the display (example: Err03), go to AUTOMATIC ELECTRONIC DIAGNOSTICS, below.
2. Plumbing bypass valve(s) must be in **service** position (all the way open or closed, as applies).
3. Inlet and outlet pipes must connect to the EcoWater System Unit inlet and outlet respectively.
4. Is the transformer plugged into a “live”, grounded wall outlet, and the power cable fastened securely?
5. The valve drain hose must be free of kinks and sharp bends, and not elevated over 8’ above the floor.
6. Is there salt in the brine tank?
7. Is the brine tubing connected? See repair parts page 26.
8. Press the SELECT keypad two times to display the hardness setting. Be sure it is the correct setting

for the household’s water supply. -- Make a hardness test of the raw water and compare with the hardness setting. Also test a conditioned water sample to verify if a problem exists. --Press SELECT twice more to return the present time display.

If you do not find a problem after making the initial checks, do MANUAL INITIATED ELECTRONIC DIAGNOSTICS, and the MANUAL ADVANCE REGENERATION CHECK.

AUTOMATIC ELECTRONIC DIAGNOSTICS

The faceplate computer has a self-diagnostic function for the electrical system (except input power and water meter). The computer monitors electronic components and circuits for correct operation. If a malfunction occurs, an error code appears in the faceplate display.

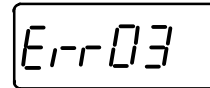

The chart below shows the error codes that could appear, and the possible defects for each code.

While an error code appears in the display, all faceplate keypads are inoperable except the SELECT keypad. SELECT remains operational so the service person can make the MANUAL INITIATED ELECTRONIC DIAGNOSTICS to further isolate the defect, and check the water meter.

POSSIBLE DEFECT

CODE	MOST LIKELY -----	LEAST LIKELY
Err 01 Err 02 Err 03 Err 04	wiring harness or connection to position switch / switch / valve defect causing high torque / motor inoperative	
Err 05	faceplate	

PROCEDURE FOR REMOVING ERROR CODE FROM FACEPLATE: 1. Unplug transformer---- 2. Correct defect---- 3. Plug in transformer---- 4. Wait for 6 minutes. The error code will return if the defect was not corrected.

CHECKING THE MODEL CODE ENTRY (See page 12)

Unplug the transformer at the electrical outlet, then plug it in again. A “beep” will sound, then the model code displays for a few seconds. The test number will then display for a few seconds, followed by the present time display.

CHANGING THE MODEL CODE

IMPORTANT: READ page 12 BEFORE CHANGING THIS CODE.

1. Enter the secondary mode...press SELECT and hold for 3 seconds.
2. Again, press SELECT and hold for 3 seconds. The current model code setting will display.
3. Use the (↑) or (↓) keypad to display the desired model code.
4. Press SELECT to set.
5. Reset the timer (page 12) and reselect other desired options.

MANUAL INITIATED ELECTRONIC DIAGNOSTICS

1. To enter diagnostics, press the SELECT keypad and *hold* for 3 seconds.

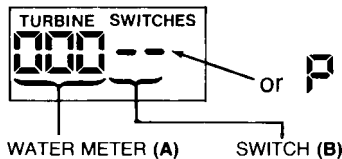

A. The first 3 digits indicate water meter operation as follows.

000 (steady) = conditioned water not in use...no flow through the meter.

-open a nearby CONDITIONED WATER faucet-

000 to 199 (continual) = repeats display for each gallon of water passing through the meter.

If you don't get a reading in the display, with a faucet open, pull the sensor housing from the valve outlet port. Pass a small magnet back and forth in front of the sensor. You should get a reading. If you **do get a reading**, disconnect the outlet plumbing and check the turbine for binding. If you **don't get a reading**, the sensor is probably defective. **CAUTION: BE SURE TO TURN OFF WATER BEFORE YOU DISCONNECT PLUMBING.**

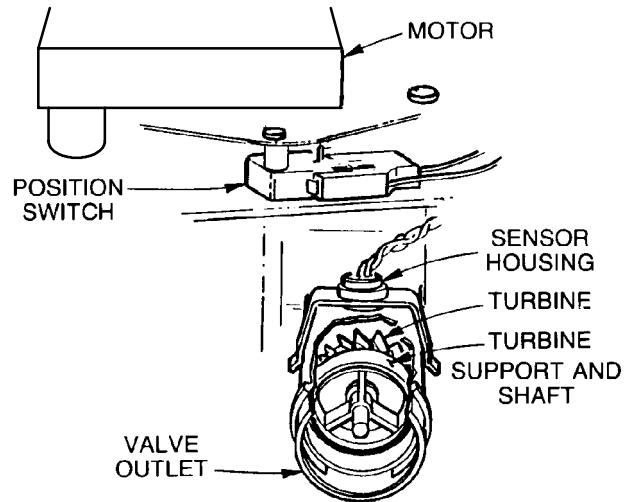

Use the RECHARGE keypad to manually advance the valve into each cycle and check correct switch operation (step **B**), and observe the valve position indicator bars (step **C**).

B. The letter (P) and dash or dashes indicate position switch operation. The letter shows if the switch is closed. A dash shows when the switch is open.

NOTE: *The position switch is closed when the plunger is depressed, open when extended.*

CORRECT SWITCH DISPLAYS	VALVE CYCLE STATUS
- -	valve in service, fill, brining, back-wash or fast rinse position
- P	valve rotating from one position to another

C. While in this diagnostic screen, the following information is available and may be beneficial for various reasons. This information is retained by the computer from the first time electrical power is applied to the face plate.

-- Press (↑) to display the number of days this face plate has had electrical power applied.

-- Press (↓) to display the number of regenerations initiated by this face plate since the SR code number was entered.

3. Press the SELECT keypad and hold 3 seconds until...

SR 22 shows.

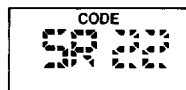

This code identifies the softener nominal capacity size. If the wrong number shows, the softener will operate on incorrect programming. Do the following as needed.

Return the present time display: Press the SELECT keypad.

Change the SR number: To display the correct SR number, press the (↑) UP or DOWN (↓) keypad. Press SELECT, and *reset the timer*.

NOTE:

If the face plate is left in a diagnostic display (or a flashing display when setting times or hardness), present time automatically returns if a keypad is not pressed within 4 minutes.

FACE PLATE REPLACEMENT: Be sure the valve is in service position (observe valve cycle indicator) when replacing the face plate.

If, after installing and programming the replacement face plate, the valve is **not** in service position, do the following to assure correct cycle orientation, or timing, between the face plate and valve.

Use the MANUAL ADVANCE procedures, page 23. With the RECHARGE keypad, advance through the recharge cycles until the valve stops in service position, and RECHARGE no longer flashes in the timer.

NOTE: The valve motor may automatically drive through several valve positions while searching for service. If an error code occurs, unplug the transformer, then plug in again.

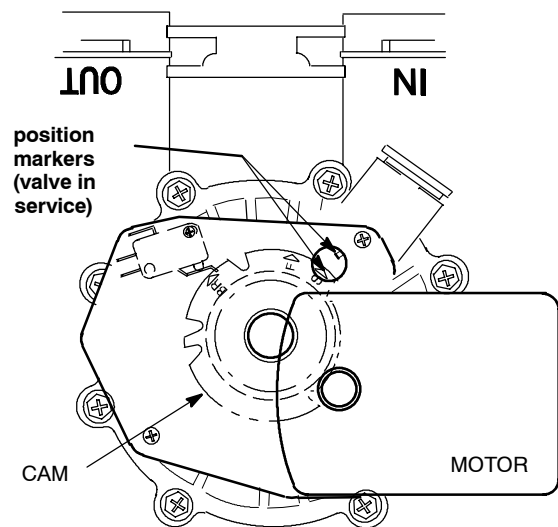

MANUAL ADVANCE REGENERATION CHECK

This check verifies proper operation of the valve motor, brine tank fill, brine draw, regeneration flow rates, and other controller functions. **Always make the initial checks, and the manual initiated diagnostics.**

NOTE: The face plate display must show a steady time (not flashing).

1. Press the RECHARGE keypad and *hold in for 3 seconds*. RECHARGE NOW begins to flash as the softener enters the fill cycle of regeneration. Remove the brinewell cover and, using a flashlight, observe fill water entering the tank.

a. If it **does not** enter the tank, look for an obstructed nozzle, venturi, fill flow plug, brine tubing, or brine valve riser pipe.

2. After observing fill, press the RECHARGE keypad to move the softener into brining. A slow flow of water to the drain will begin. Verify brine draw from the brine tank by shining a flashlight into the brinewell and observing a noticeable drop in the liquid level.

NOTE: Be sure a salt bridge is not preventing water with salt contact.

- a.** If the softener does not draw brine:
- nozzle and/or venturi dirty or defective.
 - nozzle and venturi not seated properly on gasket.
 - restricted drain (check drain fitting and hose).
 - defective nozzle and venturi seal.
 - other inner valve defect (rotor seal, rotor & disc, wave washer, etc.).

NOTE: If water system pressure is low, an elevated drain hose may cause back pressure, stopping brine draw.

3. Again press RECHARGE to move the softener into backwash. Look for a fast flow of water from the drain hose.

An obstructed flow indicates a plugged top distributor, backwash flow plug, or drain hose.

4. Press RECHARGE to move the softener into fast rinse. Again look for a fast drain flow. Allow the softener to rinse for a few minutes to flush out any brine that may remain in the resin tank from the brining cycle test.

5. To return the softener to service, press RECHARGE once more.

Before working on the valve, **turn off the water supply** and **disconnect from electrical power**.

TO RELIEVE PRESSURE

- **3 VALVE BYPASS:** Close the inlet valve and open a soft water faucet. Then close the outlet valve and open the bypass valve.

- **OPTIONAL BYPASS:** Slide the bypass valve stem to bypass position. Loosen the 3 hex head screws (see A in drawing) toward the backside of the valve to allow pressure water to bleed out. Catch the water with a rag.

DISASSEMBLY

To remove a part or group of parts, refer to the valve drawing. A common screwdriver or nut driver, Phillips screwdriver and pliers are the only tools needed to completely disassemble.

SERVICING THE VALVE

Inspect all o-rings, seals and gaskets for wear or defects.

Inspect the bottom surface of the rotor and disc for scratches, chips or wear.

NOTE: If replacement is needed, be sure to use the current replacement part.

ASSEMBLY

Be sure all parts are in place and in the proper position. Lubricate ALL o-rings and seals with FDA approved silicone grease. To install the rotor seal, first place the seal into the valve groove, rounded side down (see cross-section). Apply a light coating of silicone grease to the seal's crossing ribs. Then, carefully center the wear strip on the seal, and push it downward onto the seal.

Install the nozzle and venturi seal and drain seal. Assemble two o-rings and the wave washer onto the rotor and disc. Then center the rotor and disc, in the valve body, on the rotor seal.

Lower the cover onto the valve body and rotor shaft. Then install the cover holding screws. **Before tightening the screws, install the valve cam and gear.** Then, **turn the rotor (CLOCKWISE ONLY) to SERVICE position.** Tighten the screws using a criss-cross pattern. If a torque wrench is available, torque to 30-40 inch pounds. Lubricate the gear on the motor, and the valve cam gear with Molykote grease, or other high quality gear lubricant. Be sure to orient the switch as shown, with the lever toward the cam.

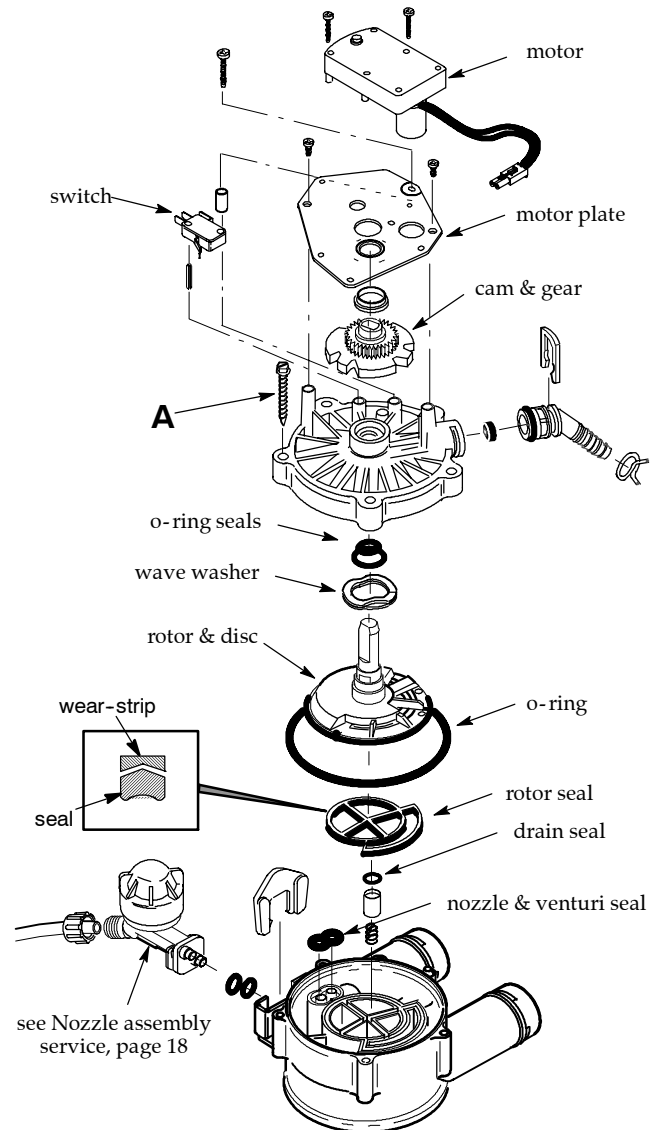

		ESD 525
RATED CAPACITY (grains @ salt dose)		15,900 @ 3.1 lbs 27,900 @ 8.8 lbs 33,000 @ 14.4 lbs
RATED EFFICIENCY (grains / lb of salt @ min. salt dose)		5,100 @ 3.1 lbs
PRESSURE DROP AT SERVICE FLOW RATE (psi)		7
SERVICE FLOW RATE (GPM)		6
INTERMITTENT FLOW RATE @ 15 PSI (gpm) ¹		9.0
INTERMITTENT FLOW RATE @ 30 PSI (gpm) ¹		13.4
MIN.-MAX. WORKING PRESSURE (PSIG)		20 - 100
MIN.-MAX. OPERATING TEMPERATURE (° F)		40 - 120
FILL CYCLE	MINUTES	²
	FLOW (GPM)	0.3
BRINING AND BRINE RINSE CYCLE	MINUTES	102 - 104
	BRINING FLOW (GPM)	.22
	BR. RNS. FLOW (GPM)	.15
BACKWASH CYCLE	MINUTES	7
	MAX. FLOW (GPM)	2.0
FAST RINSE CYCLE	MINUTES	3
	MAX. FLOW (GPM)	2.0
HIGH CAPACITY RESIN LOAD	POUNDS	47
	CUBIC FEET	.9
SALT STORAGE CAPACITY - POUNDS		200

¹ Intermittent flow rate does not represent the maximum service flow rate used for determining the softeners rated capacity and efficiency. Continuous operation at flow rates greater than the service flow rate may affect capacity and efficiency performance. The validity of these flow rates is verified by NSF.

² Fill time is automatically determined by the timer, depending upon the capacity operating level.

This system conforms to NSF/ANSI 44 for the specific performance claims as verified and substantiated by test data. The efficiency rating is only valid at the stated salt dosage. This softener was efficiency rated according to NSF/ANSI Standard 44.

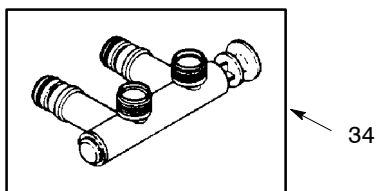
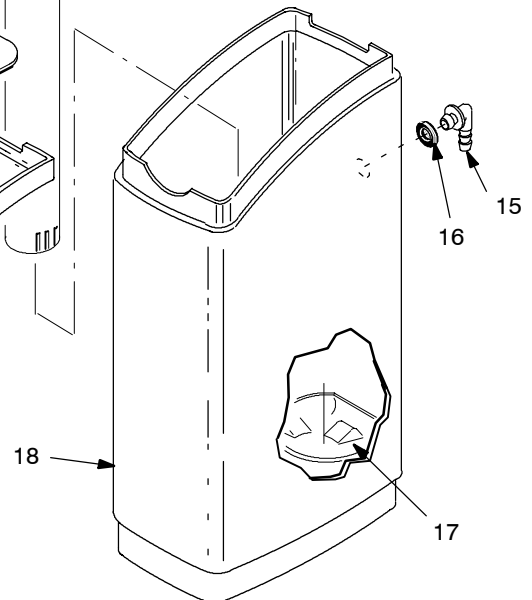
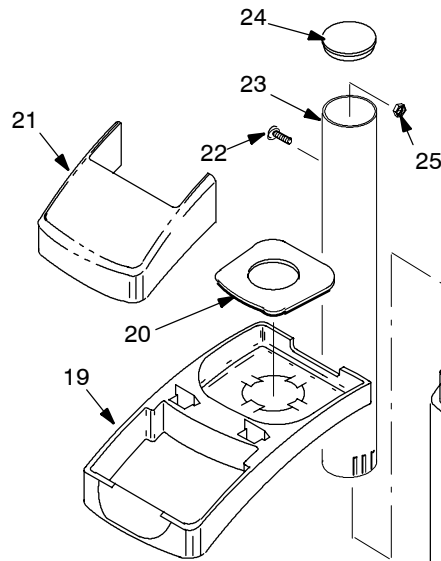
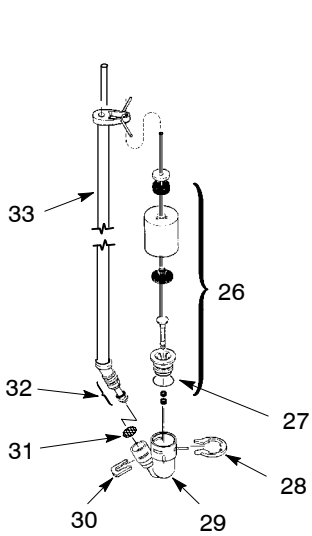
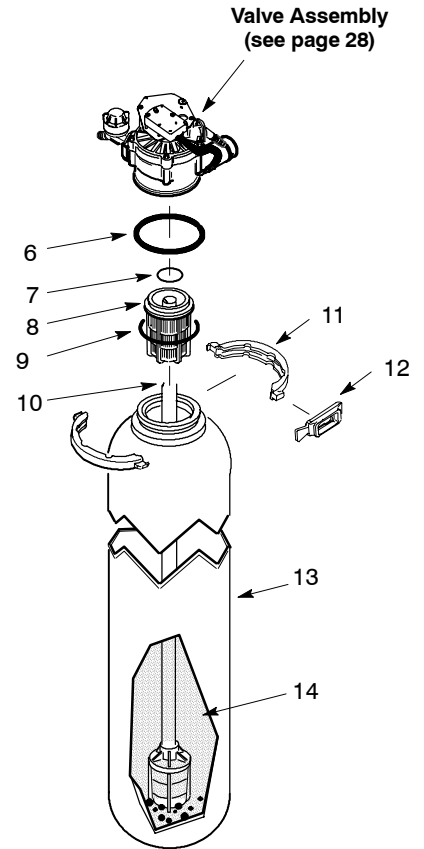
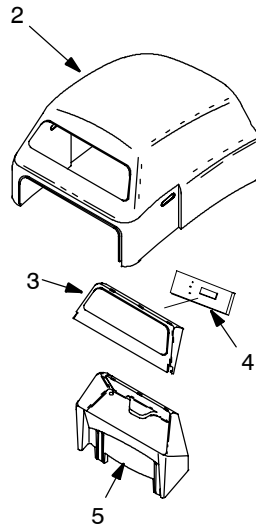
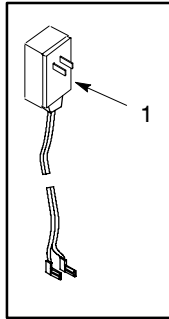

KEY NO.	PART NO.	DESCRIPTION
1	7252373	Transformer, 24V-10VA
2	7218662	Top Cover
3	7210509	Faceplate (order following decal)
-	7214692	Decal
4	7238418	Repl. PWA
5	7211173	Faceplate Support
6	7170296	O-ring Seal, 2-7/8" x 3-1/4"
7	7170254	O-ring, 13/16" x 1-1/16"
8	7077870	Top Distributor
9	7170270	O-ring, 2-3/4" x 3"
10	7105047	Repl. Distributor (bottom)
11	7176292	Clamp Section, 2 req.
12	7088033	Clamp Retainer, 2 req.
13	7113066	Resin Tank, 10" dia. x 35"
14	0502272	Resin, 1 cu ft (stand. mesh)
-	0501741	Resin, 1/2 cu ft (stand. mesh)
15	1103200	Hose Adaptor
16	9003500	Grommet
-	0900431	Hose Clamp (not shown)
17	7141205	Tank Base
18	7218604	Brine Tank
19	7210397	Rim

KEY NO.	PART NO.	DESCRIPTION
20	7214244	Vapor Barrier
21	7210389	Salt Hole Cover
22	7219587	Screw
23	7109871	Brinewell
24	7155115	Brinewell Cover
25	7219595	Washer
26	7113008	Float, Stem and Guide Assem.
27	7170288	O-ring, 15/16" x 1-3/16"
28	1205500	Clip
29	7092252	Brine Valve Body
30	7080653	Clip
31	7131365	Screen
32	7113016	Tubing Assembly, BV
33	7095470	Brine Tube
34	7129871	Bypass Valve ①
■	7116488	Brine Valve Assem. (incl. key nos. 26 through 33)
■	7108118	Hose, 1/2" I.D. Drain (order length needed)

① optional part.

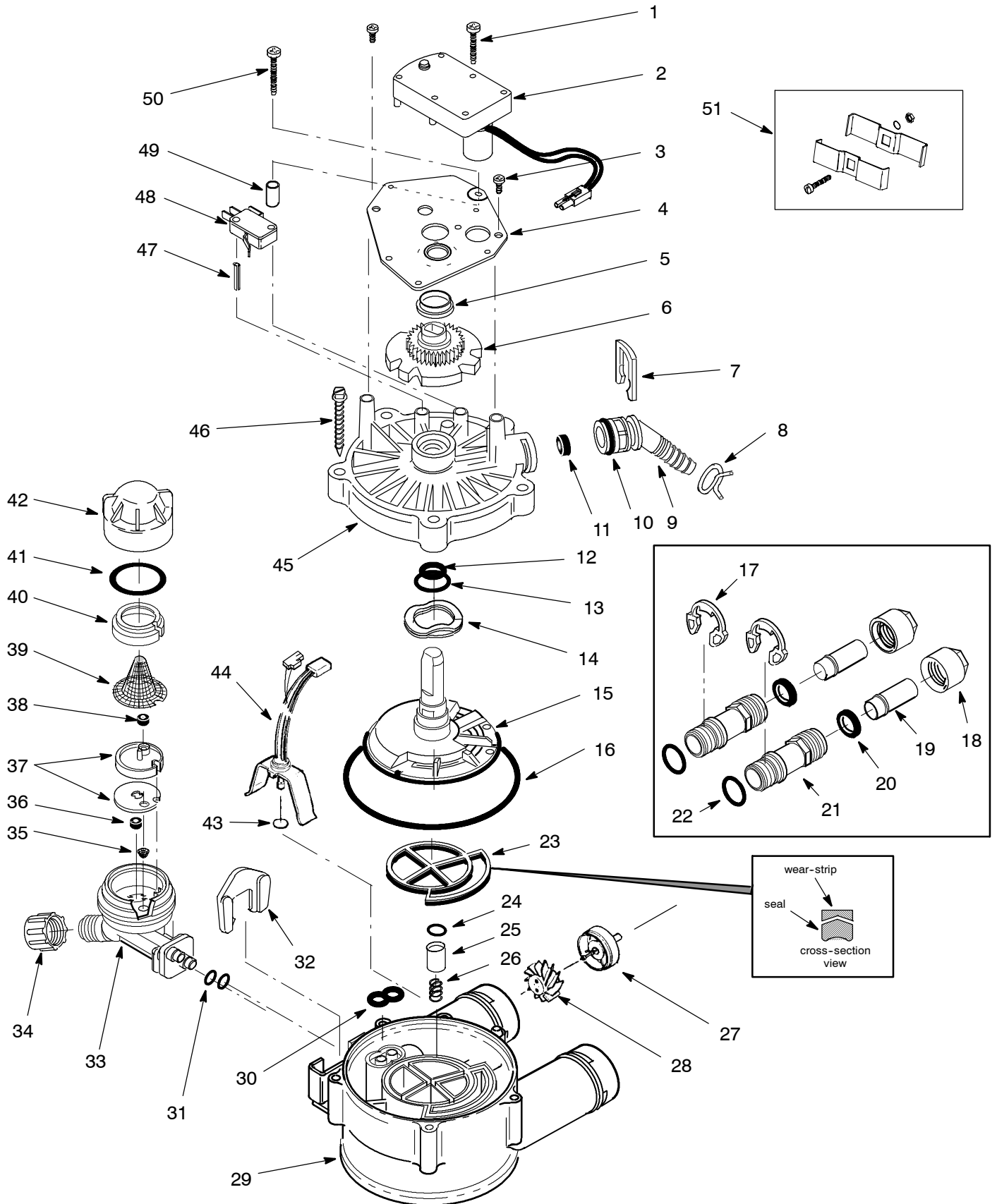

KEY NO.	PART NO.	DESCRIPTION
1	7224087	Screw, #8-32 x 1" (2 req.)
2	7234731	Motor (incl. 2 ea. of Key No. 1)
3	0900857	Screw, #6-20 x 3/8 (2 req.)
4	7231385	Motor Plate
5	0503288	Bearing
6	7113927	Cam and Gear
7	7142942	Clip (Drain)
8	0900431	Tubing Clamp
9	7024160	Drain Hose Adaptor
10	7170327	O-Ring, 5/8 x 13/16
11	0501228	Flow Plug
12	7170238	O-Ring, 7/16 x 5/8
13	7170212	O-Ring, 3/4 x 15/16
14	7082087	Wave Washer
15	7199232	Rotor & Disc
16	7170246	O-Ring, 3-3/8 x 3-5/8
17	7116713	Clip (2 req.)
18	0507369	Installation Nut (2 req.)
19	0507615	Installation Tube (2 req.)
20	7170335	Washer (2 req.)
21	2207800	Installation Adaptor (2 req.) (incl. 2 ea. of Key No. 22)
22	7170288	O-Ring, 15/16 x 1-3/16 (2 req.)
23	7134224	Rotor Seal
24	7170204	O-Ring, 3/8 x 9/16
25	7092642	Plug (Drain Seal)
26	7129889	Spring
27	2204101	Turbine Support and Shaft
28	7117858	Turbine
29	7082053	Valve Body

KEY NO.	PART NO.	DESCRIPTION
30	7081764	Seal (Nozzle & Venturi)
31	7170319	O-Ring, 1/4 x 3/8 (2 req.)
32	7081201	Retainer (Nozzle & Venturi)
33	7081104	Nozzle & Venturi Housing
34	1202600	Nut - Ferrule
35	7095030	Cone Screen
36	1148800	Flow Plug, .3 gpm
37	7147706	Nozzle & Venturi Gasket Kit
-	7204362	Gasket (only)
38	7084607	Flow Plug, .15 gpm
39	7146043	Screen
40	7167659	Screen Support
41	7170262	O-Ring, 1-1/8" x 1-3/8"
42	7199729	Cap
43	9000803	O-Ring
44	7235371	Sensor Housing & Wiring Asm
45	7085263	Valve Cover
46	7074123	Screw, #10-14 x 2 (5 req.)
47	7077472	Expansion Pin
48	7030713	Switch
49	7117816	Spacer
50	7070412	Screw, #4-24 x 1-1/8 (flat head)
51	7248706	Ground Clamp Kit
◆	7137507	Nozzle & Venturi Assy. (incl. Key Nos. 33, and 35 through 42)
◆	7129716	Seal Kit (incl. Key Nos. 12, 13, 23, 24 & 30)

◆ not illustrated

LIMITED WARRANTY
EcoWater Systems LLC Advantage Warranty
ESD 525 Water System

Congratulations! You have just purchased the highest quality water conditioning product on the market. To register your warranty, complete the enclosed Warranty Registration Card and mail it within 30 days of purchase.

To whom is this warranty extended?

EcoWater Systems LLC warrants its products to the original owner and guarantees that the products will be free from defects in materials and workmanship from the original date of installation.

How does my warranty work?

If, during the respective warranty period, a part proves, after inspection by EcoWater, to be defective, EcoWater will, at its sole option repair or replace that part at no charge, other than normal shipping, installation or service charges.

What is covered by the warranty?

EcoWater Systems LLC guarantees that, for the LIFETIME of the original owner, the MINERAL TANK will not rust, corrode, leak, burst, or in any other manner fail to perform its proper function and that, for a period of TEN YEARS, the SALT TANK will be free of defects in materials and workmanship and will perform its proper function and that, for a period of THREE YEARS, the VALVE BODY, ELECTRONIC FACEPLATE and ALL OTHER PARTS will be free of defects in materials and workmanship and will perform their normal functions.

How do I obtain warranty service?

Should you need service, your local, independent EcoWater Dealer is only a phone call away.
PHONE: _____

To obtain warranty service, notice must be given, within thirty (30) days of the discovery of the defect, to your local EcoWater Systems dealer.

If I need a part replaced after the factory warranty expires, is the replacement part warranted?

Yes, EcoWater Systems LLC warrants FACTORY REPAIRS as well as all REPLACEMENT PARTS for a period of 90 DAYS. This warranty does not include normal shipping, installation or service charges.

Are any additional warranties available?

We are pleased to say, YES! EcoWater Systems LLC sells an EXTENDED, PARTS ONLY WARRANTY for the ELECTRONICS portion of your product. This warranty is called the "Perfect Ten" and extends the three year warranty on the electronic FACEPLATE, WIRING HARNESS, DRIVE MOTOR, TRANSFORMER, POWER CORD, SENSOR HOUSING, and MICRO SWITCHES to a total of TEN YEARS from the date of original installation. Your local dealer will provide details regarding this warranty or will refer you to the factory for additional information.*

General Provisions

The above warranties are effective provided the water conditioner is operated at water pressures not exceeding 125 psi, and at water temperatures not exceeding 120°F; provided further that the water conditioner is not subject to abuse, misuse, alteration, neglect, freezing, accident or negligence; and provided further that the water conditioner is not damaged as the result of any unusual force of nature such as, but not limited to, flood, hurricane, tornado or earthquake. EcoWater Systems LLC, is excused if failure to perform its warranty obligations is the result of strikes, government regulation, materials shortages, or other circumstances beyond its control.

*THERE ARE NO WARRANTIES ON THE WATER CONDITIONER BEYOND THOSE SPECIFICALLY DESCRIBED ABOVE. ALL IMPLIED WARRANTIES, INCLUDING ANY IMPLIED WARRANTY OF MERCHANTABILITY OR OF FITNESS FOR A PARTICULAR PURPOSE, ARE DISCLAIMED TO THE EXTENT THEY MIGHT EXTEND BEYOND THE ABOVE PERIODS. THE SOLE OBLIGATION OF ECOWATER SYSTEMS LLC UNDER THESE WARRANTIES IS TO REPLACE OR REPAIR THE COMPONENT OR PART WHICH PROVES TO BE DEFECTIVE WITHIN THE SPECIFIED TIME PERIOD, AND ECOWATER IS NOT LIABLE FOR CONSEQUENTIAL OR INCIDENTAL DAMAGES. NO ECOWATER DEALER, AGENT, REPRESENTATIVE, OR OTHER PERSON IS AUTHORIZED TO EXTEND OR EXPAND THE WARRANTIES EXPRESSLY DESCRIBED ABOVE.

Some states do not allow limitations on how long an implied warranty lasts or exclusions or limitations of incidental or consequential damage, so the limitations and exclusions in this warranty may not apply to you. This warranty gives you specific legal rights, and you may have other rights which vary from state to state. This warranty applies to consumer-owned installations only.

GUARANTEE
BOND

The Safeco Insurance Company of America has issued it's bond in the form shown below, guaranteeing full performance by EcoWater Systems LLC

SAFECO INSURANCE COMPANY OF AMERICA, hereinafter called "Surety," guarantees unto Bank of New York as Trustee holding said Guarantee Bond under the terms of a Trust Agreement dated April 9, 2003, for the use and benefit of original purchasers of residential EcoWater Systems Units within the Continental United States, as described herein, that EcoWater Systems LLC, will discharge the obligations of the "EcoWater Bonded Parts and Service Guarantee Policy."

PROVIDED, HOWEVER, that:

1. Liability of Surety hereunder shall not exceed the sum of FIVE HUNDRED AND 00/100th DOLLARS (\$500.00) as to any one installation, and shall not exceed the sum of FIVE HUNDRED THOUSAND AND 00/100th DOLLARS (\$500,000.00) in the aggregate, and
2. There shall be no liability hereunder as to any purchaser to whom there has not been issued at the time of installation and purchase completed registration card which is enclosed with a facsimile of this bond, and who has not returned such card in accordance with this guarantee.
3. Claim must be made by such original purchaser in writing within 30 days from the expiration of these guarantees upon EcoWater Systems LLC, PO Box 64420, St. Paul, MN 55164, to perform the terms of said guarantee, and notice of any default on such guarantee must be sent to Surety at its address by Registered Mail.

SAFECO INSURANCE COMPANY OF AMERICA

This is to certify that the original of the above guarantee and bond is on file with Bank of New York.

BANK OF NEW YORK
As Trustee